

tabú

my fear and yours

directed by **Firenza Guidi**

Cast:

Adie Delaney:	Amaranta Ursula, the girl that knows no fear
Natalia Fandino:	Ursula, the originator, and eater of earth
Marco Fiera:	José Arcadio Buendía, the originator, her husband, and the man who looks for the magic in things
Vanina Fandino:	Petra Cotes, the woman who multiplies animals just by looking at them
Shaena Brandel:	Fernanda, the woman who was raised to be a queen
Marcella Manzilli:	Remedios, the beauty
Barnz Munn:	José Arcadio, the son that ran away with the gypsies
Petri Ekqvist:	Aureliano, the great revolutionary
Kadja Karjalainen:	Rebeca, the girl from over the mountains
Howie Morley:	Melquiades, the last of the travelling gypsies
Kevin McIntosh:	Arcadio, the daydreamer
Simone Riccio:	Pietro Crespi, the Italian music teacher
Peter Swaffer-Reynolds:	Francisco the Man Musical Director
Gareth Marshall:	Aureliano Segundo Keyboard, guitar, base guitar & vocals
Dylan Leonard:	Gaston Percussion & vocals
Louise Marsland:	Sofia Saxophone, clarinet & vocals
Andy North:	Mauricio Babilonia Keyboard, guitar, base guitar, electric double bass & vocals

Preset:

Curtains – up
Ginger gate down
Fred gate up
Band stage ramp and Bridge ramp down.
Bridge Ramp by wardrobe
Band Ramp slung under Ginger.
Rocking chair on Ginger
Natalia's teacup, saucer and bottle on SR Fred
Natalia's other cup & saucer USR Ginger
Spaghetti & tobacco in colander in basket – basket line tied to tech curtain pole
Mud (broken up chocolate slices) in large metal bowl and bowl set on flying rig
Wash Basin on SRC of Ginger
Vanina's white umbrella on rocking horse trolley
Shaena's white umbrella in USR Ginger leg
Vanina's shoes on bridge
Natalia - Umbrella line set to bridge
Howie, Natalia and Vanina - Tight wire set in suitcase
Barnz - Swinging trapeze and quick release pre rigged
SR Bridge Angel line on bridge, SL angel line left hanging until after pre show then to Barnz kp
Ginger angel lines to Ginger
Fred angel lines to Fred
Bridge Down and Wheel set SR
Marco - Penny Farthing DSL band stage
German Wheels – 1 parked by bar, 1 parked by band stage.
Trapeze box behind Barnz king pole
Curtain box behind Flying centre curtain
Mats set by rigging bay and box office (including 1 tumble mat).
1 tumble mat under band stage
1 trampoline mat under band stage
1 trampoline mat by hazer
Kevin's rope on bar curtain pole
All Marcella's toys in the cage and cage set in the shop SR Ginger
Pram & Howie's white umbrella SL Ginger

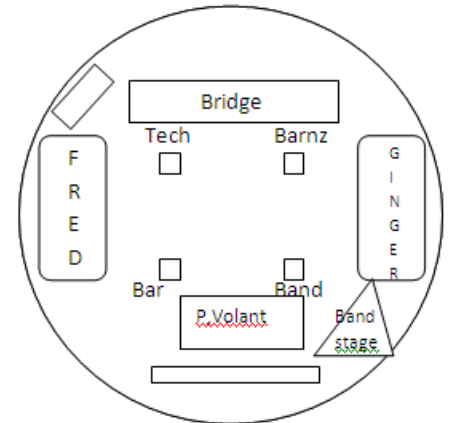

Rain dress – water and air – set on truss trolley by props bay.
Adie's hoops set in shop
Kevin's white dress set under Fred

Pre-show

Howie wandering with suitcase

Marco on Penny Farthing

Shaena sat on Fred gate

Natalia crosses from Fred to bridge

Performers come out at Beginners

- 9 minutes before – mbi's on
- 10 minutes before – Foghorn 1

Flying

Bridge

Marco – penny farthing

Adie on bridge

Marco & Simone – trampette

Adie & Vanina – gym ball

Gareth & Adie

Howie

Andy

Kevin & Louise

Kadja (trampette)

Vanina & Dylan

Petri

Natalia & Marco

Saul

Shaena – punch bag

- 7 minutes before – Foghorn 2

Simone left juggling on bridge

Helen & Leif go to comas & put gels over mbi's

All go to comas

When 2 are left to go up – Claire sets gels on mbi's at bridge

When all the comas have been set

Mbi's out

Simone set on Jesus Christ – Petri waiting to turn him

Helen gives Shaena the radio mic

Shaena:

Ladies and Gentlemen Welcome to tabú, the bullring, this is a promenade performance, don't worry you won't get your feet wet. There are stewards to guide you. Please switch off your mobile phones and no photography as your flashes may blind us. Keep your feet safely on the ground while we float and twirl over the dusty banks. Thank you and enjoy the show.

Marco takes mic & takes it to band stage

B/O

1 bar of “ooo oos”

4. Text, live – Gareth
A Body suspended in space (Natalia)

Snow Hare

It's been raining for 4 years 11 months and 2 days.

On the day they were going to kill me I got up at five thirty in the morning.

I dreamed I was going through a grove of timber trees where a gentle drizzle was falling

And for an instant I was happy in my dream

But when I woke up I felt completely spattered with bird shit

I'm always dreaming about trees, I hadn't recognized the omen

Last week I'd dreamed I was alone in a tinfoil airplane

And flying through the almond trees without bumping into anything

I was happy then

I was happy in my dream

Natalia, Howie,
Vanina, Shaena &
Kevin
Coma
Choreography:

Layout
Turn to the left
Turn to the right
Invert upside down
Return to layout

Simone on Jesus Christ – Petri turning him slowly

5. The storage: The space opens further to reveal a forest of levitating bodies

On (Natalia's feet away from wires) layout:

- Kadja drops down from truss

- Centre curtain comes down – Chris & Saul release & put in box
- Bar & Band curtains down – Marcella & Marco band, Stewards bar
- Audience brought under comas
- Light goes out on bridge side – Simone leaves & Petri gets into wheel on bridge
- Saul takes box round to other centre curtain
- Centre curtain dropped into box – box laid off outside wardrobe
- Tech & Wardrobe curtains down – Stewards
- Bridge up

Natalia repeats sequence

Invert upside down

Layout

Turn to left

Layout

Sharp upper body tuck

- Marcella whistle

Live text repeated in sections

6. The pram: open the space

The Arrival

- Marco parts audience with penny farthing – Marcella following on trike
- Simone brings on pram from Ginger, Marcella joins
- Pram centre – Simone (Ginger), Marcella (Fred) pull out strop rig & lay it out on floor
- Marco strikes pram around flying rig & back to Ginger

7. The swinging trapeze comes down like a fury

The Arrival continued

Trapeze Pre rigged on quick release system

Preparation: Adie walks out on washing line clipped to both the centre line and her lunge

Barnz releases trapeze

Adie flies out from washing lines counterweighted by Barnz
Petri leaves bridge

Routine:

- Tombe full twist to ankles
½ twist to ankles
Up to stand
- Grand tombe to front balance
Toe hang
1 hocks to sit
- Leapfrog to stand
- Ankles
Pirouette to sit

De-Rig:

Pre-recorded text - Adie:

I'm afraid of forgetting everything happens for a reason. If I forget this I cannot accept the dark, yeah I have physical fears, but I'm not afraid.

- Natalia on floor– tech kp
- Vanina on floor – barnz kp
- Kevin on floor – band kp
- Kadja on floor – bar kp

Ratchets broken

- Marco rides under on Penny-farthing
- Simone catches Adie
- Simone gets box & brings it centre
- Marco drops in centre line
- Petri gets angel line & clips onto centre line over top of rig
- Shaena – barnz kp
- Barnz – band kp
- Howie – bar kp
- Saul – tech kp
- Natalia & Simone move box over strop rig
- Barnz & Saul counterweight trapeze down
- Simone & Marcella feed trapeze into box

- Ratchets unclipped then clipped to wire rig
- 4-point unclipped then clipped to wire rig
- Barnz, Howie, Saul & Shaena pull up to dead & ratchet – Marco counterweights Petri up - Marcella strikes box to under bridge
- Fred loops paged away
- Marco locks Petri off

8. The Strop Crossing

Bei-Bei

If I should say
That every time I see you
You run away
That's every time I see you

1. Simone (Barnz kp), Kevin (Band kp)
 - Company come from rig – Simone & Kevin go to hand loops, company assemble outside king poles (Fred)
 - Simone & Kevin have high 5 moment in centre
 - They walk towards Ginger – at full stretch they turn & swing towards Fred – on return company run towards them
 - Simone & Kevin swing 6 – 9 times
 - Company run 4 times
 - On 3rd time Barnz & Adie have lift (Ginger)
 - On 4th time – Howie & Kadja – centre
 - Natalia & Vanina lift (Fred)
 - Marco & Shaena lift (flying)
2. First switch
 - Howie takes Simone's loop, Marcella pages in Tech kp loop
 - Kevin jumps on Kadja ready for switch
 - Howie & Marcella have high 5 moment then swing in opposition from bridge to flying – company run in same direction

- 4 swings – Marco holds Marcella in planch – lets go – on return Marcella knocks Marco over
- Howie pages his loop back to kp
- Adie & Marcella switch, Kadja & Kevin switch
- Adie & Kadja swing towards Fred
- On 2nd swing Kevin matches Adie's jump at swing apex - Simone gets into position to catch Kadja's hand
- Simone get's Kadja, Kevin gets Adie – revolutions
- 2 revolutions then company run through "doors"
- Barnz pages in barnz kp loop, Saul pages in bar kp loop
- Marco clips into centre line
- Kevin gets rope
- Company disperse

3. Diorama

- Vanina & Adie switch, Shaena & Kadja switch
- The 4 swing clockwise – start small & get bigger
- 5th swing Marco starts to bring Petri down
- 3 swings
- Marcella brings Shaena's hand loop from band kp
- Barnz & Saul page their loops back – Adie pages Vanina's, Marcella pages Shaena's
- Shaena swaps with Petri - centre line
- Barnz goes to tech kp & clips into angel line

4. Diamond

- Shaena does diamond (ragging) in centre – Marco counterweights
- Diamond established – lift to pull down the washing
- Barnz & Marco counterweight Shaena over the rig to angel line position
- Vanina swaps with Marco

De-rig

- Natalia brings on pram
- Petri (band kp), Howie (bar kp), Adie (tech kp) & Kadja (Barnz kp) break ratchets, unclip & lower
- Simone, Marco, Natalia & Saul unclip & load into pram
- Natalia takes pram off

- Kevin swings centre

9. Kevin's Solo

Sleep

Sleep is the first house somebody gave me
 Sleep is the first house somebody gave me
 Take it as a sign, the ship is coming.

Sun days and meadow dreams
 Women count their fingers
 The girl next door is dancing well
 In the cellar of the house

Nothing but sea scales
 To bless the landed fellows.
 If the ship is coming it's
 Slender as a knife.

Small streets may appear
 Dog tails in Winter
 They wave like the hands
 Of the moon and her tears.

Sleep is the first house somebody gave me
 Sleep is the first house somebody gave me
 Take it as a sign, the ship is coming.

Preset

- Shaena sets wheel under Ginger
- Adie & Kadja wait to lift Ginger gate
- Marco sets wheel under Fred
- Howie on Fred
- Natalia & Saul wait to lift Fred gate
- Marcella gets trike with box attached to back

End of Kevin's routine

- Toe climb
- Ankle hang
- Wrap for curly whirly
- Curly whirly x 4
- Down to floor
- Scissors
- Down

Sleep is the first house

Dylan text:

I'm afraid of heights.

I never used to be, but when it hits you, that's it.

I'm left alone on the edge.

Funny how survival instinct kicks in

- Marcella whistles & comes in on trike
- Vanina drops in centre line
- Simone puts rope in box
- Kevin unclips angel line – Simone unclips centre & puts on sand bag
- Vanina takes up centre line
- Gates go up

Wheels out

10. Ensemble German Wheel

Days in the Wood

Every day I stand by the shore

Waiting for your presence

Every day I stand by the shore

Hoping you'll come home

There are days when I'm by the shore

And I think you're coming

Then again I'm no longer know
That I'll recall your name.

If at all you come to the shore
Know for sure that I'm waiting
To tell the truth I know longer know
What I'm waiting for.

Every one knows times they are changing
Friends of mine are telling me so
Years go by and I am still waiting
Standing here where I saw you go

When you come home
Will I remember?
How to kiss you
Now that I'm older
Everything is strange
Nothing is the same

Nothing is the same x 4

If you never want to lose me
If you never want to lose me
Never, never let me go.

1. Howie & Marco cross from Fred to Ginger – Howie starts on Fred – hard stop – Marco slips in - Hats
Shaena cross from Ginger to Fred in single splits or Star
Simone goes to bridge wheel
2. Howie & Marco return (Fred) in kamikaze
Natalia & Vanina take wheel from Shaena & cross – Vanina pike over to sit – short return (Fred) – Vanina in front balance – see saw x 3
3. Howie & Marco return (Ginger) – stop – handstand
Natalia & Vanina – short return (Ginger) - Natalia – pike over to stand
4. Howie & Marco return (Fred) – Howie planch

- Natalia & Vanina return (Fred) – Natalia planch – Vanina goes to bridge
5. Wheels turn
Simone on bridge wheel
 6. Natalia & Shaena – doubles split or back to back to Bridge –
Natalia goes to Ginger
Howie & Marco – kamikaze to flying
 7. Kevin & Shaena star back to centre
Marco & Howie back to centre
 8. Wheels turn
Simone sets wheel tech side & swings off bridge
 9. Marcella & Adie – come to outside – roll to Ginger
Marco & Howie towards Fred – Simone jump over
 10. Pick up Natalia – roll to Fred – the bus
Simone climbs up Marco – straddle sit on top
Simone – horizontal handstand – takes Howie’s hat - “hello girls” – returns hat – kiss
Wheels go into tight wire rig

11. Vanina tight-wire

- Vanina – on bridge (when she’s safe – bridge down)
throws boots down & puts on heels
Opens umbrella
- Howie- Brings on suitcase with wire in, Rigs main wire, Signal Simone to turf
- Adie – Up Barnz KP – when signalled by Barnz hauls up 4 point and clips on to Wire deads.
- Kadja - Up Tech KP – when signalled by Barnz hauls up 4 point and clips on to Wire deads.
- Bridge set – Vanina begins organic returns on bridge
- Natalia - Up Band KP – when signalled by Barnz hauls up 4 point and clips on to Wire deads.
- Shaena – Up Bar KP – when signalled by Barnz hauls up 4 point and clips on to Wire deads.
- Petri – On Bridge to pass wire over it.
- Barnz - On Floor, Bar + Band KP clips 4 point onto support wires, clips floor wires onto yellow connector. Signals Shaena

and Natalia, and Adie and Kadja at the correct times to haul up 4 point.

- Kevin – On floor, Tech KP, gives Marcella 4 point from tech KP, pulls wire from bay over the Bridge. Climbs bridge & attaches Umbrella line to the umbrella
- Marcella – On floor, Barnz KP, clips on both tech and Barnz 4 point onto wire from bay, helps Howie to clip on main wire.
- Simone – takes wire out of bay and passes it to Petri, tirms the wire to the orange marks.
- Stewards drop Fred gate, then Ginger gate

Vanina steps over wire – music drop

Vanina's Text:

Music change

Vanina steps onto wire

Marco singing

Blind Brazil Love

Will you let me know you I'm a monster?

Will you let me know you I'm a monster?

I'm blind with love

I'm blind with love

I'm blind with love

I'm blind with love

I'm waiting in the garden

I'm knocking at your door

Please let me in

Let down your golden hair

What are you doing with those scissors?

I'm blind with love

I'm blind with love

I'm blind with love

I'm blind with love

I'm waiting in the garden
I'm knocking at your door
I want to climb this vertical sunset

I'm blind with love...

Routine:

Kevin – On washing line

Natalia – on Umbrella line swaps with Marcella

- Vanina steps onto the tight wire
- Reaches centre, turns with umbrella
- Kevin centre washing line
- Umbrella flies up
- Takes off high heels
- Shout's up at Kevin
- Leans on wires at end point
- Puts flat shoes on – walks back to other end
- Comes centre, takes off Dress – goes to other end
- Calls for basket
- Walks back, Basket flies in
- Takes out tobacco and spaghetti,
- Eats Spaghetti
- Throws colander to Simone
- Bounces with basket x 2, basket flies out
- Rolls cigarette crouched towards Ginger
- Layout - Shaena, Adie, Kadja, Simone, Kevin and Petri release cigarette papers.
- Kevin leaves down (tech kp)
- Simone passes up the red umbrella
- Bouncing & dancing
- Splits
- Passes red umbrella to Simone
- Tirfor broken by Martin
- Dismount to Kevin's shoulders

What are you doing with those scissors?

De Rig – As rig apart from the following:

- Petri Up Band king pole
- Howie unclips wire at bridge end
- Marcella lowers umbrella
- Shaena comes down tech kp & takes over umbrella line.
- Marco leaves bandstage to lift Natalia
- Marcella crosses to Barnz kp and unclips line from umbrella and attaches sandbag to umbrella line.
- Shaena pulls out umbrella line when sandbag is on

Kevin and Vanina Dancing

Vanina leaves 3 times last time taking umbrella
She goes between tech & barnz kp, Kevin dancing alone
Drum roll - music stop
Chris drops in trapeze & waits with bowl
Kevin decomposes
Marcella unclips umbrella & Vanina leaves

12. An unstoppable desire to eat earth again (Natalia: static trapeze 1)

Snow Hare

Ooo Ooos

Natalia standing under the trapeze
Natalia climbs onto Marco's shoulders to reach trapeze

Saul does bottom ratchets on bridge trampoline

Routine:

Hang, one arm
Belly rolls
Spin
Side hang
Swing up and stand on trapeze
Natalia's pre-recorded text

Yo, la peor todas
La más fea
La más difícil, la menos inteligente
Tengo miedo de que los otros prefieran a otra antes que a mí.
Entonces pruebo toda, pruebo de superar las pruebas más difíciles, las más imprevistas, las más peligrosas.
Así la gente dirá, Muy bien! Ves que podés y, entonces siento un deseo irresistible de comer tierra hasta que piedras y gusanos se incierten entre los dientes.
Nadie sabrá nunca, que mi fuerza es solo mentira.
Tengo miedo del mundo,
Pero nada me para.

Rocking

Swing round rope x2

Stop rocking

Arabesque

Standing round the world

Stand

Crouch

Chris drops bowl from flying rig

Stands & eats earth

- Marcella sets horse & herself on Bridge, Howie takes position on line
- Adie & Vanina get into stiff skirts position on bridge trampoline
- Shaena, Kadja & Simone get umbrellas

Music change

Barnz singing

Je pleur parce que je t'aime

Je pleur parce que je t'aime

Je pleur parce...

Dylan singing

Oonce, oonce, oonce, oonce

Wind

Natalia drops the bowl – Marco catches it.

13. Marcella with donkey on the bridge

Oonce Oonce

Natalia drops bowl back to Marco, he runs to bridge & throws bowl away

Howie (tech) and Marco (costume) at either end to pull horse up and down platform.

- Simone unicycles behind bridge & sets wheel under Fred
- Shaena & Kadja do one crossing then rig angel lines to Ginger gate – more crossings
- Umbrella crossings through audience.
- Kevin on Jesus Christ

Natalia rocking on trapeze watching

Starts standing between trusses, horse beneath her on platform.

Routine:

Launches butterfly

Kevin catches butterfly & launcher – goes to Jesus Christ

Climbs down

Whistle – bridge up

Horse moves off to tech end

Marcella chases

Marcella moves centre

Horse goes between her legs

Marcella sits on the horse backwards

Game - She goes to it, it goes the other way

Bridge set

Marcella under bridge – horse over head

Chase

Sidesaddle from costume to tech

Chase

Marcella centre with horse

Marcella lifts horse above her head

Adie & Vanina planch

Petri & Kadja do lift centre, stewarded by Shaena – Shaena passes Kadja her umbrella
Music decomposes to:

Barnz singing

Wind reprise

There's a wind in the moon tonight
And my love is out sight
Shadows in the hallways
There's a wind in the moon
tonight

14. **Pietro Crespi: German Wheel**

You know I know

Barnz Text:

I'm afraid of losing control, not just the things around me, I can't control the wind, I can't control how people behave around me, I'm afraid of losing control of myself, that's the most scary thing I've ever come across, this is the thing I fear the most.

- Barnz and Saul ratchet bridge trampoline

Simone hangs off Fred gate – Kevin & Petri lower gate – Simone drops onto wheel held by Marco

- Kevin & Petri drop gate to floor when Simone starts, then go to top of Fred & drop arch
- Howie unties lines on horse platform & tidies them

Gareth singing

You know I know
You know
And I know that I know you too.

Rolling, rolling
Faster, faster
Red, pink, orange and blue

Sometimes I know
Sometimes I know
What I should do.

He knows I knows
He knows
That he knows that I love him too.

Wrote his name
On my balloon
It's pitching in the blue.

Sometimes I know
Sometimes I know
What I should do.

She knows I know
She knows
That she knows that I don't like you.

Touched her lips
And that was good
And then I watched her die.

Sometimes I know
Sometimes I know
What I should do.

Routine:

Starting from above
2 revolutions towards sitting to Ginger
Return back forward roll then jump
Sitting, Out of sitting couple of steps towards Ginger
Out into belly with forward roll

Jump into sitting and going backwards
Going into the wheel and straight up
Form top straight legs down on abdominals
Twisty legs
Forward roll in pike (knees)
Ending lying on the platform
Back to centre with Marco helping roll
Coming out from lying to
Back roll, from the platform onto the bar to the platform again
Twice
One rocking
From the platform forward roll on the next bar
Belly into Half turn
Spiral ending near Ginger

Boomdiboom ciao!
Boomdiboomboom ciao!

- Petri drops bridge trampoline
- Saul & Petri, Vanina & Howie ratchet
- Chris drops flying trampoline
- Chris & Adie, Marcella ratchet

Fizzy, fizzy let's get dizzy...

Pike Forward roll to sitting
Back onto platform
Forward roll to sitting
Pike Forward roll to sitting
Walk in wheel toward Fred

- Marco & Natalia come to spot salto

Back somersault.

Whitewash

15. Aerial Crossings

The Bones

Let's do it again.

The Bones

Positions at start:

- Adie on bungees between Barnz & band kps
- Barnz on barnz kp
- Marco on floor near band kp clipped into centre line
- Howie tech kp
- Marcella bar kp
- Vanina top of bridge trampoline
- Petri on bridge German wheel?
- Kadja flying rig
- Natalia on Ginger
- Shaena on Fred clipped into angel lines
- Saul tech kp
- Simone SR of Fred gate with wheel

Order

1. Howie first
2. Marcella salto cross
3. Howie & Marcella centre bounces
4. Catch & high 5
Adie & Shaena go
5. Howie crosses to other side of trampoline
Marcella goes up to washing line bungees
Vanina crosses top of bridge trampoline & clips into bungees
6. Marco goes from floor to bridge trampoline
6 bounces – feet first
tuck spin
Running on spot
Shaena down – clips angel lines onto Fred gate
Flat back
7. Marco down - takes centre line to Natalia
8. Simone crosses from Fred to Ginger
Howie goes to Fred for Bulls

Kevin goes to Ginger for Bulls

9. Natalia splat

10. Marco catches Natalia centre – unclip centre line & Barnz takes up

De-rig

- Petri & Saul break ratchets (tech kp) – Petri counterweights trampoline up
- Vanina breaks ratchets (barnz kp)
- Adie breaks ratchets (band kp) – Marco counterweights trampoline up
- Marcella breaks ratchets (bar kp)
- Simone goes to Fred gate – Marcella goes to Ginger gate

16. The Bulls

The Bull

Gareth Text:

I look into the bullring
grab my fears by the horns
sometimes I shake them
knot them together to keep them still
sometimes I fight back
sometimes I give myself up to it like a lost lover
Until a sudden shaft hits me in the face
and scars me for life

- Howie & Kevin start Bulls bubbling
- Shaena on band kp whipping
- Adie on tech kp whipping
- Vanina on floor or bridge with radio mic
- Natalia on floor?
- Saul & Vanina break ratchets
- Petri counterweights bridge trampoline up
- Saul counterweights Fred gate up – Petri tails
- Adie & Marcella break ratchets
- Marco counterweights Ginger gate up

- Barnz counterweights flying trampoline up
- Bulls out
- They move towards centre
- Marco comes from the flying rig into centre facing bridge
- Howie & Kevin – 360 on axis of wheel to bring them upright either side of Marco – Howie faces towards flying rig, Kevin faces bridge
- End of bulls – Howie's upright, Marco lifts arms

B/0

- Money thrown – Natalia breaks up bulls
- Barnz & Chris bring in cradle box

17. Kevin dancing on Ginger

The Calling

- Wheels docked
- Shaena & Howie rig door
- Kevin goes to Ginger
- Marco and Barnz pull out cradle lines
- Marcella (bar), Adie (band), Vanina (tech), Barnz (Barnz) clip 4-point onto cradle. Then pull ratchets out.
- Marcella (bar), Adie (band), Barnz + Vanina (Barnz), Natalia + Marco (tech) Haul up cables to trapeze deads
- Natalia + Marco (tech), Adie (band), Marcella (bar), Barnz + Vanina (barnz) clip floor ratchets on
- Natalia (tech), Barnz (Barnz), Adie (band), Marcella (bar) ratchet together – Marco calls
- Chris sets lunge
- Barnz & Saul clip on double lunge
- Marco takes box away

18. The Virgin and the great Revolutionary: Hot serious-Cradle

Gareth Text:

She was such a good girl.

Good grades.
Good friends.
Good school.
Good rules.

She was such a good girl.
But a painted surface and a fool.
A lie, a mug, a fraud.
She wanted life to be hot
To try and try and never get shot.

Yea, the worst, the hardest, the scariest.
She wanted life to be pushed.
But never fling back, in pain or a mess,
And walk the walk, and walk the walk of total control.

She was such a good girl.
In the ground she could go without dirtying her hands.
A spotless surface, and the craze inside that said no sleep,
no eat, no people, just toys

She was such a good girl
She survived it all, but never quite found the power at all.
Good grades.
Good friends.
Good school.
Good rules, but never quite beat the fear to be a fool.

Petri climbs rope to cradle.
Howie (angel lines (tech)) and Saul (centre line) lift Kadja up
Then pause before counter weighting her across to the cradle.
Kevin leaves Ginger

Beautiful, Bright, Stillness (The Garden)

Shaena & Louise sings:

Beautiful, bright stillness
Be me you
In you I shall be here
And in you, am not you
Here I am

Chris lunges

Ensemble make their way to positions after 1st trick.

Routine:

Kadja steps onto cradle turn, Petri takers off her coat drops it.

Kadja takes off Petri's jacket, drops it, undoes belt, Petri turns 360.

Petri Kisses Kadja

Petri sits.

1. Back flip
Mount
2. Cartwheel
Splits
Toe hang – back corbette
One toe hang
Double swan to sit
3. Back flip
Front salto
4. Roll down
Front tuck
Flip to back balance
Flip to tuck
Angel
Front salto to heels
Double swan
5. High bar
Back salto
Pike mount

All ensemble in position & penny-farthing goes up
Kiss

Ensemble positions in LX order:

1. Shaena – On Ginger – centre with white umbrella
Vanina – On Fred centre with white umbrella
2. Kevin – On penny-farthing flown between Barnz and tech king poles Angel lines. Rigged under bridge and clips on there, he gets onto bike before riding forward until under the cupola then counter weighted up by Barnz
3. Bridge up - Marco and Natalia - on bridge on donkey platform pulling themselves back and forth with an umbrella
4. Marcella sitting on Petite Volant cradle with large duck on a line & Simone standing behind her
5. Adie – On bungees on washing line between bar and band king poles standing on trampoline, with umbrella open and eating an apple
6. Howie horizontal on tech kp

Howie and Saul counterweight Door to cradle, Kadja steps onto doorway
Door returns to start position

The Calling Reprise

Gareth text:

She was such a good girl.

Kadja looks back

But never quite beat the fear to be a fool.

B/O

Door dropped

Shaena:

Ladies and Gentleman. There will now be a 20-minute interval and the bar is open. Thank you

Interval Changes

1. De Rig Cradle.
Marco, Barnz, Chris break cradle & drop into box
2. Saul drops bike – stewards clear to Ginger – Kevin unclips
3. Barnz & Shaena rig hoop. Shaena cleans it
4. Drop bridge. Switch on projector in Bridge. Rig bridge ramp. Level bridge & raise to cinema dead
5. Howie sets fire equipment.
6. Howie sets hula hoop on Fred
7. Adie sets fire hoops on Ginger
8. Set trampoline mats by flying rig and Band
9. Leif replugs floor lamps & cupola par can for rain dress, & profiles for Adie. He unties Howie zip line (tech kp) for Saul
10. Lissy & Bill move projector onto Fred
11. Helen strikes colander & bowl to props bay
12. Shaena sets fire umbrellas on Ginger
13. Louise & Kadja get radio mics

Second Half

Clearance

B/O

Pete starts Ooos

Snow Hare reprise

The Tableau

Ensemble and Band enter one by one and form tableau on Ginger all with umbrellas.

Kadja singing & moving slowly through audience

1. Marco (band stage) and Natalia (ramp)
2. Howie (usc)
3. Barnz (ladder)
4. Adie (ladder)
5. Petri (band stage)
6. Gareth (band stage)
7. Shaena (ladder)
8. Vanina (band stage)
9. Andy (band stage)
10. Dylan (ladder)
11. Simone (ladder)
12. Kevin (ladder)
13. Kadja (leaves mic – ladder)
14. Louise (band stage)
15. Marcella (ladder)

Tableau positions on Ginger:

SR

Saul
Dylan Kadja Petri
Kevin Kadja
Simone Shaena Natalia Marcella
Adie Barnz Marco

SL
Louise
Andy
Gareth Vanina
Howie

(on top platform)

Tableau Text:

Gareth – I'm afraid I'll never be good enough
& settle for a lesser place
Louise – I'm afraid of life passing me by.
Of waking up one day having no stories to tell
Howie – What is fear?
When it's the very thing that makes me feel
alive?
Adie – I get scared of what other people think.
I forget that I'm almost invincible
Marco – I have the power to change lives.
My fear and yours
Saul – I'm afraid of not being able to watch her grow.
It all changes when it's no longer you alone

Andy – I'm afraid that where I'm going doesn't exist
Dylan – I'm afraid of heights
Louise – I'm afraid of life passing me by
Gareth – I'm afraid I'll never be good enough
Barnz – I have the power to bring him back
Adie – I have the power to be completely
One hundred per cent me

Marcella starts shouting

Vanina –
Simone –
Marcella –
Kadja –
Petri –
Kevin – I can make my leave meaningless
Howie – I'm afraid of the fine line
Between ecstasy and hysteria

Marcella last on high platform. She lifts the horse "hoil"

Company – "hoil"

AV stills on tent above Ginger

17. The large hoop (Shaena)

The Edge of the Wilderness

Adie laughs
Barnz doughnut roll off Ginger.
Shaena gives umbrella to Kevin
Kadja passes mic to Shaena.
Marcella passes horse to Natalia
Band return to band stage, ensemble leave Ginger

Shaena live text:

I can take a deep breath and forget about it
Let it flow
Like water under bridges

Shaena walks down gate

Or I can hurt you back
Bounce that rage back to your face
Watch the blood rise in your cheeks
And steel
turn your eyes to snow

Hoop flies in
Shaena comes centre

I can control the pain
and I can look at you
In that cruel way
That will forever raise a wall
between our very breaths

Shaena gives the mic to Marco & walks to Hoop
She pushes it away
Shaena climbs onto rope – Barnz takes her up

Howie singing:

Here I stand on the edge of the wilderness
It's my affair
So it doesn't matter what I stand on
Anyone could be, stepping in
It's the only thing that matters
What's left for me?
Who will know if it changes?

The worst thing is I can't remember her name. You can just about cope with the bedpans, the telly, and Mrs So-and-so in the bed next door going on about her Fred. At least life would be more enjoyable if you could have a bit of sugar in your tea. So the next time I take her a little bag of sugar lumps, she's over the moon about it, she hides them in the bedside cabinet. Life is sweet again.
Life is sweet again.

Here I stand at the edge of the wilderness
If it's my affair
Will it really matter what I stand on?
Anyone could be, stepping in
It's the only thing that matters
What's left beneath?
Do we really know if it changes?

Trouble is her body can't cope with sweetness, the hyperglycaemic reaction will probably kill her. She hates it all the boredom the discomfort the frustration the view from the only window. Cross your heart and wait to die.

Here I stand on the edge of the wilderness...

I see her every week, I listen to her and I put just a little bit of sugar in her tea.

Routine:

Standing on top of the hoop – up

Drums

Holding rope – down – touches floor just as Howie starts singing

Run to Ginger

Swing centre

Walkover x 2

Back balance up

Front balance down

Spin in long arm

Up & spin

Spin

Front hang over hoop – shaky shaky

Roll over

Climb up side

Long arm hang from top

Pike up to toe hang

Drop dress – Marco collects

Up to top of hoop – front straddle over rope

Salto from top

Meat hook

Front slide down side & roll x 2

Down to floor

Run round – up & down

Pushes hoop away

Catches & floor walk

Spin up in Leonardo

Down

Long arm up from top

Long arm up from top with irrational legs

Spinning Egyptian lift - up

Straddle to splits – down

Just a little bit of sugar in her tea.
Spins hoop, hoop flies up spins by itself
Organic return walk to Barnz
Kisses Barnz

Hoop in
Howie balances hoop with one hand.
Vanina drops in end to Marcella
Marcella puts rope over Howie's shoulder & sandbag on centre line
Tarn strikes hoop to USL Ginger
Vanina pulls up centre line

18. Trampoline rig and Kevin in White dress

Empty Locker Reprise

Kevin in white dress on Ginger
AV: Kevin dancing on tent above Ginger

Rig:

- Shaena changes into white dress
- Marco (bridge) and Saul (flying) lower trampolines.
- Kadja attaches her bungees to the angel lines between Barnz and tech king poles and climbs tech king poles.
- Petri clips into coat hanger
- Simone (Barnz), Adie (Band), Marcella (bar), Marco (Tech) Clip on the strops.
- Trampolines lowered horizontal, Shaena runs through the middle with Adie's Hoop.
- Howie sets rope
- Natalia (tech), Vanina (Barnz), Dave (Bar), Adie (Band) clip on floor ratchets, Simone and Steward pull trampolines together, all ratchet on Marco's signal
- Simone (Barnz), Adie (Band), Marcella (bar), Marco (Tech) Clip on the trapeze ratchets, all ratchet on Marco's signal
- Saul goes to tech kp & clips into angel line
- Barnz pulls up Kadja's angel lines
- Natalia, Vanina, Saul, and Howie (and Stewards) bring on mats

- Howie tucks rope into mat pocket
- Adie, Marco, Howie & Marcella receive and set mats on trampolines.
- Natalia clips bungee onto wire
- Vanina clips into long bungees between barnz & band kp
- Shaena clips into high bungees on washing line between band & bar kp
- Barnz lowers in centre line, Howie clips on.
- Marco (tech kp), Simone (barnz kp), Adie (band kp), Marcella (bar kp)

When all are in position Marco raises hat to band
 Drum Roll – Kadja & Petri move to centre of washing line

19. Trampolines and Aerial bungees

Old is The Moon

Gareth Singing

Old is the Moon
 As she crumbles and falls

Down below
 Down beneath
 With these emerald teeth

She puts on her gown
 It's a gown of black snow
 And she scratches the ground

Down below
 Down beneath
 With these emerald teeth

On first note of song all jump down from their positions

- Howie in the centre turns 360 smoking a cigar.

- Marco jumps from king pole (tech) onto the trampoline – Howie flies up
- Kevin stays on Ginger
- Marco bounces round trampoline cartoon legs. He bounces off and Adie bounces round, she bounces off, Simone bounces round, he bounces off, Marcella bounces round, she bounces off.
- All four Sylvester cat run round the trampolines in unison. Howie pulls out rope
- Marco and Adie bounce together. Barnz walks up king pole.
- Simone and Marcella join, Marco and Adie jump onto the middle, Adie forward rolls then back rolls up into handstand, Howie grabs Adie's foot.
- Skiing – 1st Marco and Simone,
- Round off back somersault from corners together, Howie comes down and raises his hat
Kevin leaves
- Sitting pitch back somersault
- Doubles somersaults – Marco & Marcella, Simone & Adie
- Marco and Simone jump around and hi-five
- Marcella and Simone back flip x6 – Music Break – aerialists into pairs
- Marco and Adie somersault over the centre
- Marcella Whistles – all go to centre, Adie stands on Simone shoulders, and Marcella stands on Marco's shoulders.

Pairs holding hands. – Kadja and Petri, Saul & Natalia, Barnz and Vanina, Shaena and Howie

De Rig/Cinema Rig:

I Really Like You

- Everyone unclips and comes down
- Barnz takes out centre line

Adie talks to audience & sits on edge of bridge trampoline. When ratchets are broken she jumps off & goes under the trampolines with gold hula-hoop

- Leif brings down Kadja – Martin catches her
- Simone, Kevin, Marcella and Marco Roll up mats. Stewards strike mats
- Simone, Kevin, Marcella and Marco break and unclip floor and trapeze ratchets and strops.
- Natalia strikes Howie's rope
- Shaena counterweights flying trampoline to cinema dead, Howie tails her
- Saul counterweights bridge trampoline up then flipped back down.

Simone kisses Adie and Marcella chases them off

Adie goes up Ginger & begins hula routine

- Marco (tech kp) and Kevin (barnz kp) unclip bridge trampoline strops and clip on 4 point,
- Marco signals Saul when they are done.
- Vanina and Natalia haul up 4 point
- Howie and Natalia attach strops to flying trampoline
- Barnz pushes trampoline into position
- Marco and Kevin attach trapeze ratchets
- Kevin, Howie and Marco go to Fred to Hula
- Kadja and Barnz attach floor ratchets at the end of Adie's routine

20. Adie Hula Hoop and the Boys.

I really like you

I really like you

I really don't like you

Simone throws hoops for Adie from Ginger

On floor under trampolines as they go up.

Throws hoop up and catches it

Throws hoop and catches it on her back

Rolls hoop along Ginger it returns to her catches it between her knees

Hula with her hand

Passes hoop around her
Rolls hoop over her shoulders
Boys appear on Fred – Howie SL, Marco C, Kevin SR
Marcella changes into tennis dress & body harness
Two hoops on her arms
One hoop
Simone throws 1st hoop
Simone throws 2nd & 3rd hoop
Simone throws 4th hoop
Boys leave Fred
Adie splits 4 hoops – 2 pirouettes
Adie gathers 4 hoops at her waist
Marco (band) & Natalia (bar) climb kps to get on cinema
She whistles
She catches hoops
Music stop

21. The Cinema

Oonce Oonce

During this scene, stewards, Chris, Barnz, Adie, Petri, Kadja & Saul set mats for petite volant

Marco (band kp) & Natalia (Bar kp) creep onto trampoline.
Shaena (Band kp) Vanina (Band kp) Simone (band kp) Kevin (Bar kp)
Chaotic pushing past each other

Oonce Oonce Oonce Oonce

Mary Poppins. Marco – Mary Poppins & Superman – Natalia grabs him by the ear & drags him back – he splats face first into trampoline

Bouncing Laughing. Marco, Simone and Vanina bounce from standing to sit and back to stand pointing and laughing at the film, Shaena, Natalia and Kevin all stand at the back laughing.

Bum Bounce Shaena bouncing on her bum laughing. – Marco pisses on bar kp

Howie drops in centre line – Marcella passes it over 4-point & climbs bar kp – she clips sand bag onto trampoline, clips bungees onto centre line & onto her harness

Indiana Jones Kevin stands in the centre and jumps off onto trampoline, scissor legs, catches the truss and scramble and turns back to sits on the truss. Repeat with Simone from sitting. Simone forward rolls off the truss with Kevin spotting.

Marcella edges out to centre of trampoline

Shaena's Scream Shaena screams – Simone clown kiss x 2 – Natalia puts hand over Shaena's mouth

Oonce Oonce Oonce Oonce

Mary Poppins. Marco Mary Poppins & Superman. Simone, Vanina and Shaena do jump at the bottom of the trampoline. Then they swap with Marco, Natalia and Kevin who do strange versions of the jump.

Train Crushing All lean back on truss and slide down to the bottom of the trampoline.

Marcella flies out.

Oonce Oonce Oonce Oonce

Mary Poppins. Marco Mary Poppins & Superman

Kerfuffle – Simone Kisses Marco everyone generally runs around trying to catch Marcella.

Petri climbs up to petite volant cradle

Kadja with Marcella's dress & Adie climb up to platform

Vanina and Kevin roll along the Screen

Marco catches Marcella. At US trampoline. Marco swings Marcella out

Barnz climbs bar kp & waits for Marcella

Marcella flies onto the top of the screen. She gestures to band, to company, to audience

Siren
B/O

22. TRAMPOLINE DE-RIG INTO FLYING

Derig

Contemporary Waltz

Gareth text:

If I could change my life to be a little more like you
Dress just like you, talk just like you
Dance just like you.
If I could dress, talk, dance just like you.
If I could make my life a little more meaningless
Just like you.

If I should stand at your door
Would you let me in and take your hand?

If I should knock at your door
Would you let me in and take your hand?

Are those the words that you said?
When you told me that you'd understand?

- Marcella clips bungees onto kp & crosses to flying platform
- Natalia & Vanina come down to DS corners
- Marco & Kevin break ratchets
- Shaena holds trampoline
- Stewards clear corridors through audience for Barnz & Chris
- Barnz & Chris walk trampoline over heads of audience
- Saul counterweights up tailed by Dave
- Howie takes up centre line, crosses & counterweights vertical trampoline up

If you knew me, would you tell me?
That my love was meant for you alone

- Howie counterweights up flying trampoline.

23. The Petit Volant

Contemporary Waltz – Rock Version

Is there something here?
Is there something there?
For me? For you?

Is there something here?
Is there something there?
For me? For you?

If you knew me, would you tell me?
That my love was meant for you alone
Meant for you alone...

Shaena & Kevin, Vanina & Howie, Simone – solo waltz & climb
Chinese Pole throughout routine
Barnz sings with band

Routine:

1. Kadja and Adie doubles swing out.
Both return
2. Adie upside down straddle to catch
Release hands
Return
3. Marcella splat centre
4. Kadja heels to catch
Return
5. Adie ali baba to cradle
6. Marcella feet catch
Salto to splat
7. Adie force out – scissors

- Return
8. Marcella au jour d'oui (1 hand on bar – Petri other hand)
Double swan up (stamps on Petri's balls)
 9. Adie legs caught by Petri, Marcella roll over Adie
Return
Adie returns.
 10. Kadja layout to Petri
Return
 11. Marcella front balance to catch
Pirouette
 12. Return
 13. Kadja back somersault dismount
 14. Marcella swing roll round platform splat
 15. Adie double somersault dismount
 16. Petri somersault dismount
 17. Triumphant salute

During routine, Saul & Marco rig Natalia's spreader bar
 Natalia wraps into trapeze gets mic & attaches it to spreader bar
 Tim & Claire bring out rain dress, take off trolley, set it between
 barnz & tech kps & attach angel lines
 Vanina leaves & gets radio mic
 Music stop
 B/O
 AV – Natalia turning on tent

24. Natalia, solo static

Snow Hare reprise – Vanina on mic & Natalia on mic

Rig:

- Saul waiting on barnz kp
- Howie climbs band kp, clips in & waits
- Saul (Barnz kp) and Howie (band kp) counterweight trapeze up
- Shaena (tech kp), Kevin (bar kp) clip on 4-point and pull it up
- Saul & Howie tighten ratchets

Routine:

Natalia wrapped in trapeze & hanging over spreader bar

As she goes up she has moment with Marco on floor

Tumble down

- Ratchets tightened & checked

Front balance

Meat hook

Drop skirt

- Vanina returns mic to tech
- Barnz drops in sand bag
- Vanina clips in & lays on rain dress

Kneeling shaking

Pike on ropes

Salto to 1 arm

Leg slide

- Howie crosses Ginger for fire preset
- Shaena changes into black dress & gets radio mic

Back balance

Side hang

Meat hook spinning

Somersault over bar

Front balance

1 arm and hocks hang

Front balance

Walk over with bar

Somersault to pike to hocks hang

Lie on rope

Standing Round the world

Lie on bar (bed)

- Howie sets up fire on Ginger

Side hang

- Howie lights Shaena's fire umbrella

Spin

Splits hang

- Shaena takes umbrella & walks centre
- Howie lights Kevin's umbrella
- Marco lights fire sticks

Meat hook to armpits

Straight back balance

- All are in position

Two elbow spins

Ends with legs up on rope, head hanging down & hands touching

Folds body down to sit

25. FIRE

Let the Rain Fall

Shaena sings first verse alone then the band join in:

Let the rain fall

Let it keep on falling

Let it rain down

And softly wash my little turtledove

Marco lights fire hoops

Marcella joins & Howie lights club

Let the sun fall

Let it keep on falling

Let it fall down

And softly burn my little turtledove

Fire positions:

- Howie on rocking chair eating fire SR
- Kevin next with fire umbrella
- Marcella on horse with fire club
- Shaena centre with fire umbrella
- Marco with 2 fire sticks eating fire (fakir)
- Adie SL with 2 fire hoops

When Marco has finished he leaves Ginger, makes sticks safe, gets his jacket & Natalia's umbrella.

As fire begins to die all make their equipment safe, Kevin & Marcella leave Ginger & start slow walk to Fred

Marco reaches Natalia just as Shaena is left as lone voice. Natalia curls off trapeze onto Marco's shoulders.

Let the rain fall
Let it keep on falling

She opens her umbrella & he carries her to Fred.

26. THE RAIN DRESS

Snow Hare reprise & the beast

Oooo Ooos

Vanina turns on rain maker
Barnz & Saul counterweight rain dress up
Tim & Claire steward
Saul clips onto dead & Barnz swaps onto Vanina's line

Gareth live text:

I sit on the bed
Put my feet on the cold pavement
Stop for a moment
An absurd body
curved like Atlas's shoulders

Vanina stands

Vanina drops down – Barnz counterweights her up & down

And an upright creature between my legs
Looking at the world
After unforeseen night exertions
Outside is still dark.
My eyes sting with invisible needles
In my mouth, the taste of a new day starting
There must be a reason to get out of bed
To put one foot in front of another
To do it

then wash
Then wash and wash
As if these many bodies did not belong to me

...

There must be a reason for getting out of bed
Day after day
And not be afraid to look at the light.

Barnz slowly drops Vanina to the floor as she reaches up to the rain
dress

And not be afraid to look at the light.

B/O

AV – Natalia face turning merging into text on tent

27. The Dance of the Revolution

The Bones – fucked up

Marco lift Natalia
Marco holds Natalia in his arms
Marco rocks Natalia like a baby
360 into positions

Vanina takes off harness & puts on dry shoes.
She joins tableau
Barnz sings with band

Let's do it again
The Bones

Dance:

Lift arms up hands together and strike down
Swing arm across the body and stop it with other hand.

Lift arms up hands together and strike down
Swing arm across the body and stop it with other hand.
2 small strikes then 1
Spin
Headbanging

<u>Centre group:</u>	<u>Shaena's Group</u>	<u>Vanina's Group</u>
Throw Adie forward.	Howie swipes at Saul	Vanina Turns Kevin
Slit throat	Howie and Kadja	Kevin and Petri in
Jesus cross	swap/ Shaena and	headlock/Vanina
Natalia jump into	Saul swap.	cracks Marcella's neck
Marco's arms x 3/	Saul picks up Shaena	Marcella pulls Petri
Adie jumps on	and spins her round/	Vanina leaps through
Simone x3	Howie lifts Kadja	Marcella spun round
	Kadja scissor kick/	Vanina spins Kevin
	Shaena jumps on	round
	Saul	
	Shaena falls back into	
	Saul's arms	
	Howie falls back into	
	Kadja's arms	

Jerky Jazz Hands
Jesus cross, slit throat
All fall
1 hand push up
360 return to starting positions

Repeat
360
Lift arms up
Top of lift
B/O

28. Curtain Call

Blind Brazil Love

Barnz & Chris join performers on Fred
Bow
Acknowledge Tech tower
Band
Stewards (tech kp)
Audience
Doughnut roll off platform
Run to Ginger
Bow
Acknowledge Tech tower & Bill
Band
Audience
Doughnut roll off platform

2nd Curtain Call

Contemporary Waltz

Repetition of Tableau on Ginger
Bow
Acknowledge band
Tech tower
Bill
Audience
Doughnut roll off platform
B/O

Shaena's final speech

